

CE EMC Test Report



(Declaration of Conformity)

For
Electromagnetic Interference
Of

Product : Inverter/charger

Trade Name : EPEVER

Model Number : UP1000-M3212/UP1000-M3222/UP1500-M3222/
UP2000-M3322/UP3000-M3322/UP3000-M2142/
UP3000-M6142/UP3000-M6322/UP5000-M6342/
UP5000-M8342/UP5000-M10342/UP6000-M10542

Prepared for

BEIJING EPSOLAR TECHNOLOGY CO.,LTD.
NO.228, BLOCK A, 2ND FLOOR, BLDG 1, NO. 3 STREET, SHANGDI XINXI
CHANYE JIDI, HAIDIAN DISTRICT, BEIJING, CHINA

Prepared by

Shenzhen ECT Testing Technology Co., Ltd.
Room 1106, Era Innovation Center, Xixiang gushu second road, Baoan district,
Shenzhen city, China
Tel.: +86-0755-23062245 Fax.: +86-0755-26609102
Website: www.Ect-lab.com

TEST RESULT CERTIFICATION

Applicant's name BEIJING EPSOLAR TECHNOLOGY CO.,LTD.
NO.228, BLOCK A, 2ND FLOOR, BLDG 1, NO. 3 STREET,
Address SHANGDI XINXI CHANYE JIDI, HAIDIAN DISTRICT, BEIJING,
CHINA

Manufacture's Name BEIJING EPSOLAR TECHNOLOGY CO.,LTD.
NO.228, BLOCK A, 2ND FLOOR, BLDG 1, NO. 3 STREET,
Address SHANGDI XINXI CHANYE JIDI, HAIDIAN DISTRICT, BEIJING,
CHINA

Product Trade N/A

Product name..... Inverter/charger

Model and/or type reference UP1000-M3212/UP1000-M3222/UP1500-M3222/
UP2000-M3322/UP3000-M3322/UP3000-M2142/
UP3000-M6142/UP3000-M6322/UP5000-M6342/
UP5000-M8342/UP5000-M10342/UP6000-M10542

Standards EN 61000-6-3: 2007 + A1: 2011/AC:2012
EN 61000-6-1: 2007

This device described above has been tested by ECT, and the test results show that the equipment under test (EUT) is in compliance with the 2004/108/EC requirements. And it is applicable only to the tested sample identified in the report.

This report shall not be reproduced except in full, without the written approval of ECT, this document may be altered or revised by ECT, personal only, and shall be noted in the revision of the document.

Date of Test

Date (s) of performance of tests Feb.11 – Feb. 15,2019

Date of Issue Feb. 15,2019

Test Result..... **Pass**

Testing Engineer :

(Ken Liu)

Technical Manager :



(Nancy Xu)

Authorized Signatory :

(kelly Jiang)

Table of Contents	Page
1 . TEST SUMMARY	5
1.1 TEST FACILITY	6
1.2 MEASUREMENT UNCERTAINTY	6
2 . GENERAL INFORMATION	7
2.1 GENERAL DESCRIPTION OF EUT	7
2.2 DESCRIPTION OF TEST MODES	8
2.3 DESCRIPTION OF TEST SETUP	9
2.4 DESCRIPTION TEST PERIPHERAL AND EUT PERIPHERAL	10
2.5 MEASUREMENT INSTRUMENTS LIST	11
3 . EMC EMISSION TEST	13
3.1 CONDUCTED EMISSION MEASUREMENT	13
3.1.1 POWER LINE CONDUCTED EMISSION	13
3.1.2 TEST PROCEDURE	14
3.1.3 TEST SETUP	14
3.1.4 EUT OPERATING CONDITIONS	14
3.1.5 TEST RESULTS	15
3.2 RADIATED EMISSION MEASUREMENT	16
3.2.1 LIMITS OF RADIATED EMISSION MEASUREMENT	16
3.2.2 LIMITS OF RADIATED EMISSION MEASUREMENT	16
3.2.3 TEST PROCEDURE	16
3.2.4 TEST SETUP	17
3.2.5 EUT OPERATING CONDITIONS	17
3.2.6 TEST RESULTS	18
3.2.7 TEST RESULTS(1000~6000MHz)	20
4 . EMC IMMUNITY TEST	21
4.1 STANDARD COMPLIANCE/SERVURITY LEVEL/CRITERIA	21
4.2 GENERAL PERFORMANCE CRITERIA TEST SETUP	22
4.3 ESD TESTING	23
4.3.1 TEST SPECIFICATION	23
4.3.2 TEST PROCEDURE	23
4.3.3 TEST SETUP	23

Table of Contents	Page
4.3.4 TEST RESULTS	24
4.4 RS TESTING	25
4.4.1 TEST SPECIFICATION	26
4.4.2 TEST PROCEDURE	26
4.4.3 TEST SETU	26
4.4.4 TEST RESULTS	27
4.4.5 Photo of Radiated Emission Test	28
5 .ATTACHMENT PHOTOGRAPHS OF EUT	29

1. TEST SUMMARY

Test procedures according to the technical standards:

EMC Emission				
Standard	Test Item	Limit	Judgment	Remark
EN 61000-6-3: 2007 + A1: 2011 /AC:2012	Radiated Emission	Class B	PASS	
EN 61000-6-1: 2007 (IEC 61000-4-2: 2008)	Electrostatic Discharge Immunity	-----	N/A	
EN 61000-6-1: 2007 (IEC 61000-4-3: 2010)	Radiated Electromagnetic Fields Immunity	-----	N/A	

NOTE:

- (1) "N/A" denotes test is not applicable in this Test Report
- (2) The power consumption of EUT is less than 75W and no Limits apply.
- (3) Voltage dip: 100% reduction – Performance Criteria **B**
 Voltage dip: 30% reduction – Performance Criteria **C**
 Voltage Interruption: 100% Interruption – Performance Criteria **C**
- (4) For client's request and manual description, the test will not be executed.

1.1 TEST FACILITY

Shenzhen ECT Testing Technology Co., Ltd.

Add. : Room 1106, Era Innovation Center, Xixiang gushu second road, Baoan district, Shenzhen city, China

1.2 MEASUREMENT UNCERTAINTY

The reported uncertainty of measurement $y \pm U$, where expanded uncertainty U is based on a standard uncertainty multiplied by a coverage factor of $k=2$, providing a level of confidence of approximately 95%.

A. Conducted Measurement :

Test Site	Method	Measurement Frequency Range	U , (dB)	NOTE
ECTC01	ANSI	150 KHz ~ 30MHz	3.2	

B. Radiated Measurement :

Test Site	Method	Measurement Frequency Range	U , (dB)	NOTE
ECTA01	ANSI	30MHz ~ 1000MHz	4.7	
		1GHz ~6GHz	5.0	

2. GENERAL INFORMATION

2.1 GENERAL DESCRIPTION OF EUT

Equipment	Inverter/charger				
Model Name	UP1000-M3212				
Serial No	N/A				
Model Difference	These samples are same except their appearance is different. So we prepare TBMK001for test only				
Product Description	<p>The EUT is a Inverter/charger</p> <table border="1"><tr><td>Operating frequency:</td><td>N/A</td></tr><tr><td>Connecting I/O port:</td><td>N/A</td></tr></table> <p>Based on the application, features, or specification exhibited in User's Manual, the EUT is considered as an ITE/Computing Device. More details of EUT technical specification, please refer to the User's Manual.</p>	Operating frequency:	N/A	Connecting I/O port:	N/A
Operating frequency:	N/A				
Connecting I/O port:	N/A				
Power Source	DC Voltage				
Power Rating	DC48V				

2.2 DESCRIPTION OF TEST MODES

To investigate the maximum EMI emission characteristics generated from EUT, the test system was pre-scanning tested based on the consideration of following EUT operation mode or test configuration mode which possibly have effect on EMI emission level. Each of these EUT operation mode(s) or test configuration mode(s) mentioned above was evaluated respectively.

Pretest Mode	Description
Mode 1	Full Load

For Conducted Test	
Final Test Mode	Description
Mode 1	Full Load

For Radiated Test	
Final Test Mode	Description
Mode 1	Full Load

For EMS Test	
Final Test Mode	Description
Mode 1	Full Load

2.3 DESCRIPTION OF TEST SETUP

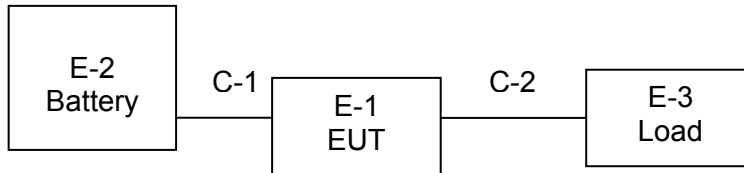

2.4 DESCRIPTION TEST PERIPHERAL AND EUT PERIPHERAL

The EUT has been tested as an independent unit together with other necessary accessories or support units. The following support units or accessories were used to form a representative test configuration during the tests.

Item	Equipment	Mfr/Brand	Model/Type No.	Series No.	Note
E-1	Inverter/charger		UP1000-M3212	N/A	EUT
E-2	Battery		N/A	N/A	Supplier
E-3	Res. Load		N/A	N/A	Load

Item	Shielded Type	Ferrite Core	Length	Note
C-1	NO	NO	100cm	
C-2	NO	NO	100cm	

Note:

- (1) The support equipment was authorized by Declaration of Confirmation.
- (2) For detachable type I/O cable should be specified the length in cm in 『Length』 column.
- (3) “YES” is means “shielded” “with core”; “NO” is means “unshielded” “without core”.

2.5 MEASUREMENT INSTRUMENTS LIST

2.5.1 CONDUCTED TEST SITE

Item	Kind of Equipment	Manufacturer	Type No.	Serial No.	Calibrated until
3	50Ω Switch	ANRITSU CORP	MP59B	6200983704	Jul. 26, 2018
4	Test Cable	N/A	C01	N/A	Jul. 26, 2018
5	Test Cable	N/A	C02	N/A	Jul. 26, 2018
6	Test Cable	N/A	C03	N/A	Jul. 26, 2018
7	EMI Test Receiver	R&S	ESCI	101160	Jul. 26, 2018
8	Passive Voltage Probe	ESH2-Z3	R&S	100196	Jul. 26, 2018
9	Triple-Loop Antenna	EVERFINE	LIA-2	11020003	Jul. 26, 2018
10	Absorbing Clamp	R&S	MDS-21	100423	Jul. 26, 2018

2.5.2 RADIATED TEST SITE

Item	Kind of Equipment	Manufacturer	Type No.	Serial No.	Calibrated until
1	Bilog Antenna	TESEQ	CBL6111D	31216	Jul. 26, 2018
2	Test Cable	N/A	R-01	N/A	Jul. 26, 2018
3	Test Cable	N/A	R-02	N/A	Jul. 26, 2018
4	EMI Test Receiver	R&S	ESCI-7	101318	Jul. 26, 2018
5	Antenna Mast	EM	SC100_1	N/A	N/A
6	Turn Table	EM	SC100	060531	N/A
7	50Ω Switch	Anritsu Corp	MP59B	6200983705	Jul. 26, 2018
8	Spectrum Analyzer	Aglient	E4407B	MY45108040	Jul. 26, 2018
9	Horn Antenna	EM	EM-AH-10180	2011071402	Jul. 26, 2018
10	Amplifier	EM	EM-30180	060538	Jul. 26, 2018

2.5.3 ESD

Item	Kind of Equipment	Manufacturer	Type No.	Serial No.	Calibrated until
1	ESD TEST GENERATOR	EVERFINE	EMS61000-2 A-V200	11040001T	Jul. 26, 2018

2.5.4 RS

Item	Kind of Equipment	Manufacturer	Type No.	Serial No.	Calibrated until
1	Signal Generator	R&S	SMT 06	832080/007	Jul. 26, 2018
2	Log-Bicon Antenna	Schwarzbeck	VULB9161	4022	Jul. 26, 2018
3	Power Amplifier	AR	150W1000M1	320946	Jul. 26, 2018
4	Microwave Horn Antenna	AR	AT4002A	321467	Jul. 26, 2018
5	Power Amplifier	AR	25S1G4A	308598	Jul. 26, 2018

3. EMC EMISSION TEST

3.1 CONDUCTED EMISSION MEASUREMENT

3.1.1 POWER LINE CONDUCTED EMISSION (Frequency Range 150KHz-30MHz)

FREQUENCY (MHz)	Class A (dBuV)		Class B (dBuV)	
	Quasi-peak	Average	Quasi-peak	Average
0.15 -0.5	79.00	66.00	66 - 56 *	56 - 46 *
0.50 -5.0	73.00	60.00	56.00	46.00
5.0 -30.0	73.00	60.00	60.00	50.00

Note:

- (1) The tighter limit applies at the band edges.
- (2) The limit of " * " marked band means the limitation decreases linearly with the logarithm of the frequency in the range.

The following table is the setting of the receiver

Receiver Parameters	Setting
Attenuation	10 dB
Start Frequency	0.15 MHz
Stop Frequency	30 MHz
IF Bandwidth	9 kHz

3.1.2 TEST PROCEDURE

- a. The EUT was placed 0.4 meters from the horizontal ground plane with EUT being connected to the power mains through a line impedance stabilization network (LISN). All other support equipments powered from additional LISN(s). The LISN provide 50 Ohm/ 50uH of coupling impedance for the measuring instrument.
- b. Interconnecting cables that hang closer than 40 cm to the ground plane shall be folded back and forth in the center forming a bundle 30 to 40 cm long.
- c. I/O cables that are not connected to a peripheral shall be bundled in the center. The end of the cable may be terminated, if required, using the correct terminating impedance. The overall length shall not exceed 1 m.
- d. LISN at least 80 cm from nearest part of EUT chassis.
- e. For the actual test configuration, please refer to the related Item –EUT Test Photos.

3.1.3 TEST SETUP

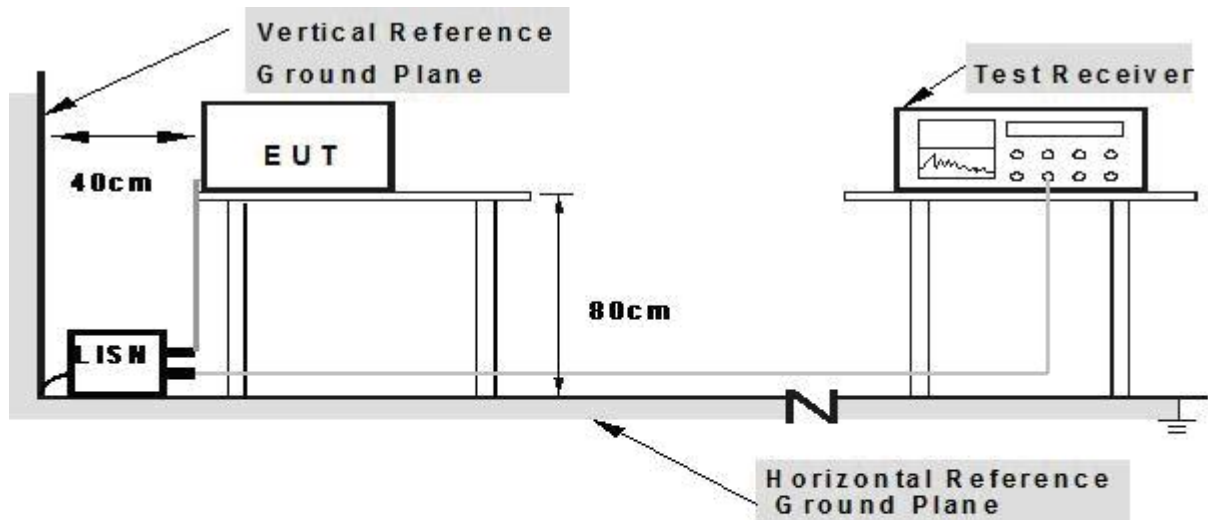

Note: 1. Support units were connected to second LISN.

2. Both of LISNs (AMN) are 80 cm from EUT and at least 80 cm from other units and other metal planes

3.1.4 EUT OPERATING CONDITIONS

The EUT tested system was configured as the statements of 2.3 Unless otherwise a special operating condition is specified in the follows during the testing.

3.1.5 TEST RESULTS

EUT :	Inverter/charger	Model Name. :	UP1000-M3212
Temperature :	26 °C	Relative Humidity :	54%
Pressure :	1010hPa	Test Date :	N/A
Test Mode :	N/A	Phase :	N/A
Test Voltage :	N/A		

3.2 RADIATED EMISSION MEASUREMENT

3.2.1 LIMITS OF RADIATED EMISSION MEASUREMENT (Below 1000MHz)

FREQUENCY (MHz)	Class A		Class B	
	At 10m	At 3m	At 10m	At 3m
	dBuV/m	dBuV/m	dBuV/m	dBuV/m
30 – 230	40	50	30	40
230 – 1000	47	57	37	47

3.2.2 LIMITS OF RADIATED EMISSION MEASUREMENT (Above 1000MHz)

FREQUENCY (MHz)	Class A (at 3m) dBuV/m		Class B (at 3m) dBuV/m	
	Peak	Avg	Peak	Avg
1000-3000	76	56	70	50
3000-6000	80	60	74	54

Notes:

- (1) The limit for radiated test was performed according to as following:
CISPR 22.
- (2) The tighter limit applies at the band edges.
- (3) Emission level (dBuV/m)=20log Emission level (uV/m).

3.2.3 TEST PROCEDURE

- a. The measuring distance of at 10 m shall be used for measurements at frequency up to 1GHz. For frequencies above 1GHz, any suitable measuring distance may be used.
- b. The EUT was placed on the top of a rotating table 0.8 meters above the ground at a 10 meter open area test site. The table was rotated 360 degrees to determine the position of the highest radiation.
- c. The height of the equipment or of the substitution antenna shall be 0.8 m; the height of the test antenna shall vary between 1 m to 4 m. Both horizontal and vertical polarizations of the antenna are set to make the measurement.
- d. The initial step in collecting conducted emission data is a spectrum analyzer peak detector mode pre-scanning the measurement frequency range. Significant peaks are then marked and then Quasi Peak detector mode re-measured, above 1G Average detector mode will be instead.
- e. If the Peak Mode measured value compliance with and lower than Quasi Peak Mode Limit, the EUT shall be deemed to meet QP(AV) Limits and then no additional QP Mode measurement performed.
- f. For the actual test configuration, please refer to the related Item –EUT Test Photos.

3.2.4 TEST SETUP

(A) Radiated Emission Test Set-Up Frequency Below 1 GHz

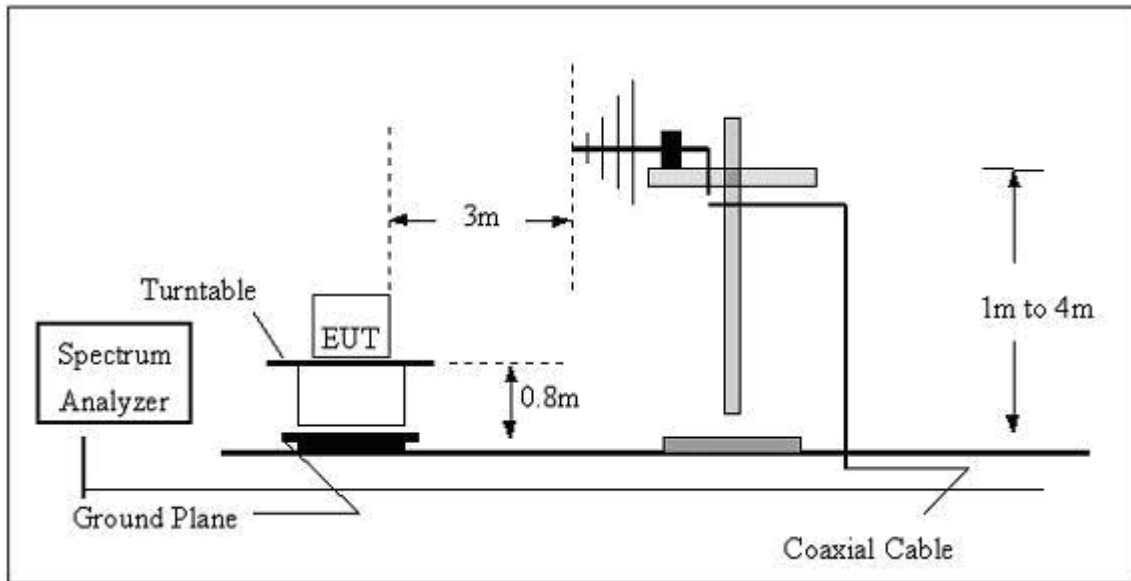

(B) Radiated Emission Test Set-Up Frequency Above 1GHz

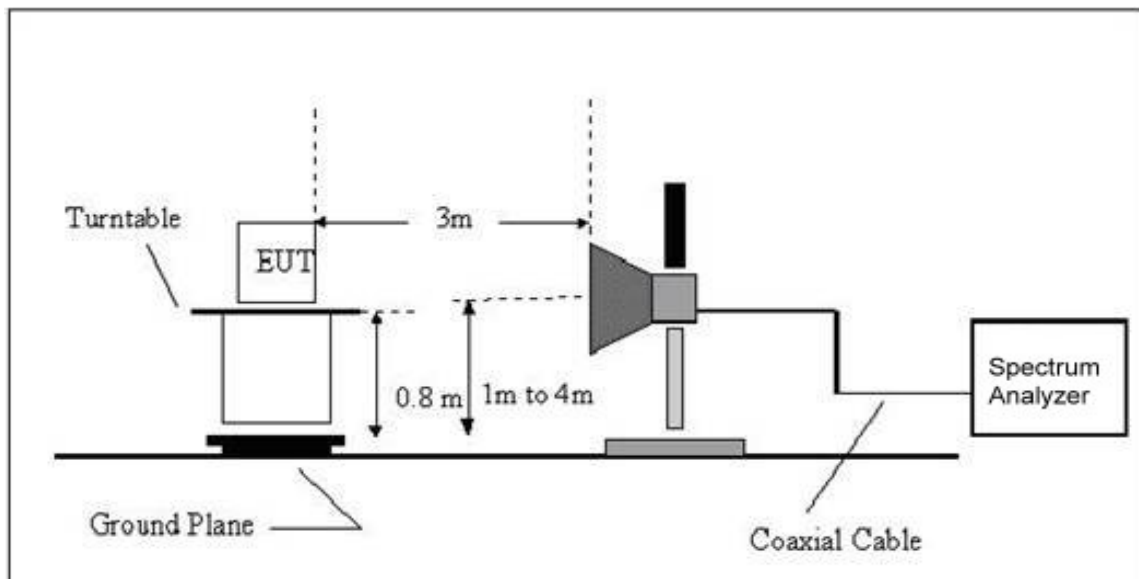

3.2.5 EUT OPERATING CONDITIONS

The EUT tested system was configured as the statements of 2.3 Unless otherwise a special operating condition is specified in the follows during the testing.

3.2.6 TEST RESULTS

EUT :	Inverter/charger	Model Name. :	UP1000-M3212
Temperature :	24 °C	Relative Humidity :	54%
Pressure :	1010 hPa	Test Date :	2019-02-13
Test Mode :	Full Load	Polarization :	Horizontal
Test Power :	DC48V		

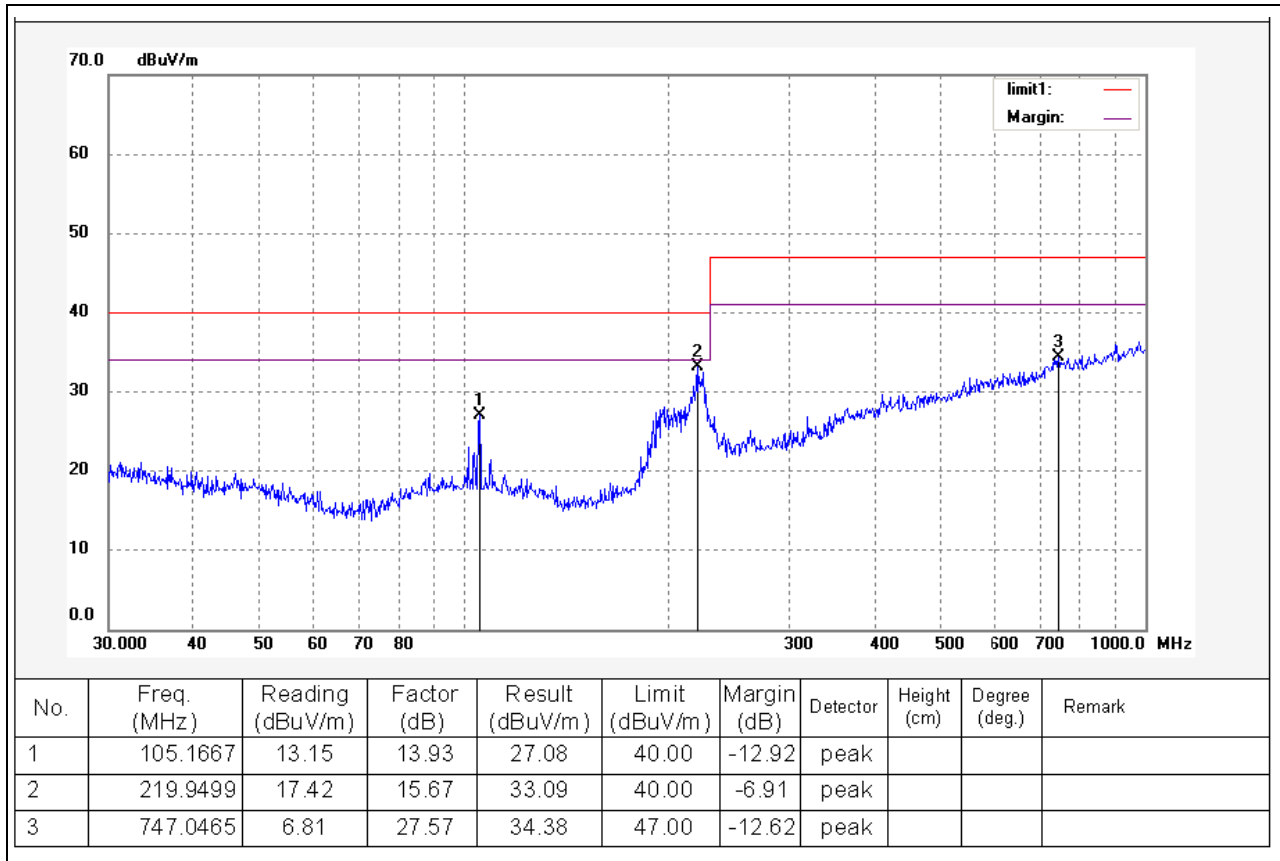

EUT :	Inverter/charger	Model Name. :	UP1000-M3212
Temperature :	24 °C	Relative Humidity :	54%
Pressure :	1010 hPa	Test Date :	2019-02-13
Test Mode :	Full Load	Polarization :	Vertical
Test Power :	DC48V		

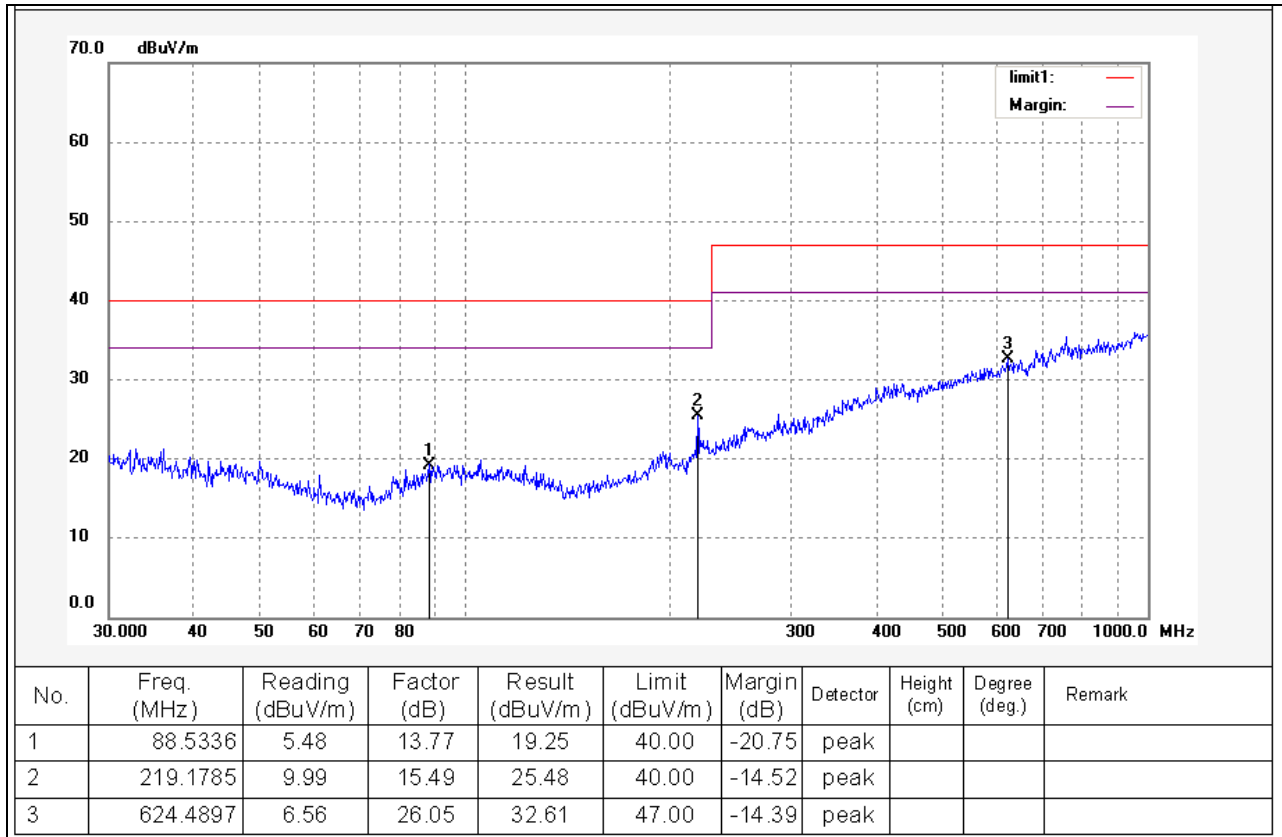

3.2.7 TEST RESULTS(1000~6000MHz)

EUT :	Inverter/charger	Model Name. :	UP1000-M3212
Temperature :	24 °C	Relative Humidity :	54%
Pressure :	1010 hPa	Test Date :	N/A
Test Mode :	N/A		
Test Power :	N/A		

4. EMC IMMUNITY TEST

4.1 STANDARD COMPLIANCE/SERVIRITY LEVEL/CRITERIA

Tests Standard No.	TEST SPECIFICATION	Test Mode Test Ports	Perform. Criteria
1. ESD IEC/EN 61000-4-2	8KV air discharge 4KV contact discharge	Direct Mode	B
	4KV HCP discharge 4KV VCP discharge	Indirect Mode	B
2. RS IEC/EN 61000-4-3	80 MHz to 1000 MHz, 1000Hz, 80%, AM modulated	Enclosure	A

4.2 GENERAL PERFORMANCE CRITERIA TEST SETUP

The EUT tested system was configured as the statements of **2.3** Unless otherwise a special operating condition is specified in the follows during the testing.

4.3 ESD TESTING

4.3.1 TEST SPECIFICATION

Basic Standard:	IEC/EN 61000-4-2
Discharge Impedance:	330 ohm / 150 pF
Required Performance	B
Discharge Voltage:	Air Discharge : 2kV/4kV/8kV (Direct) Contact Discharge : 2kV/4kV (Direct/Indirect)
Polarity:	Positive & Negative
Number of Discharge:	Air Discharge: min. 20 times at each test point Contact Discharge: min. 200 times in total
Discharge Mode:	Single Discharge
Discharge Period:	1 second minimum

4.3.2 TEST PROCEDURE

The test generator necessary to perform direct and indirect application of discharges to the EUT in the following manner:

- a. Contact discharge was applied to conductive surfaces and coupling planes of the EUT.

During the test, it was performed with single discharges. For the single discharge time between successive single discharges was at least 1 second. The EUT shall be exposed to at least 200 discharges, 100 each at negative and positive polarity, at a minimum of four test points. One of the test points shall be subjected to at least 50 indirect discharges to the center of the front edge of the horizontal coupling plane. The remaining three test points shall each receive at least 50 direct contact discharges.

If no direct contact test points are available, then at least 200 indirect discharges shall be applied in the indirect mode. Test shall be performed at a maximum repetition rate of one discharge per second.

Vertical Coupling Plane (VCP):
The coupling plane, of dimensions 0.5m x 0.5m, is placed parallel to, and positioned at a distance 0.1m from, the EUT, with the Discharge Electrode touching the coupling plane. The four faces of the EUT will be performed with electrostatic discharge.

Horizontal Coupling Plane (HCP):
The coupling plane is placed under to the EUT. The generator shall be positioned vertically at a distance of 0.1m from the EUT, with the Discharge Electrode touching the coupling plane. The four faces of the EUT will be performed with electrostatic discharge.
- b. Air discharges at insulation surfaces of the EUT.

It was at least ten single discharges with positive and negative at the same selected point.

4.3.3 TEST SETUP

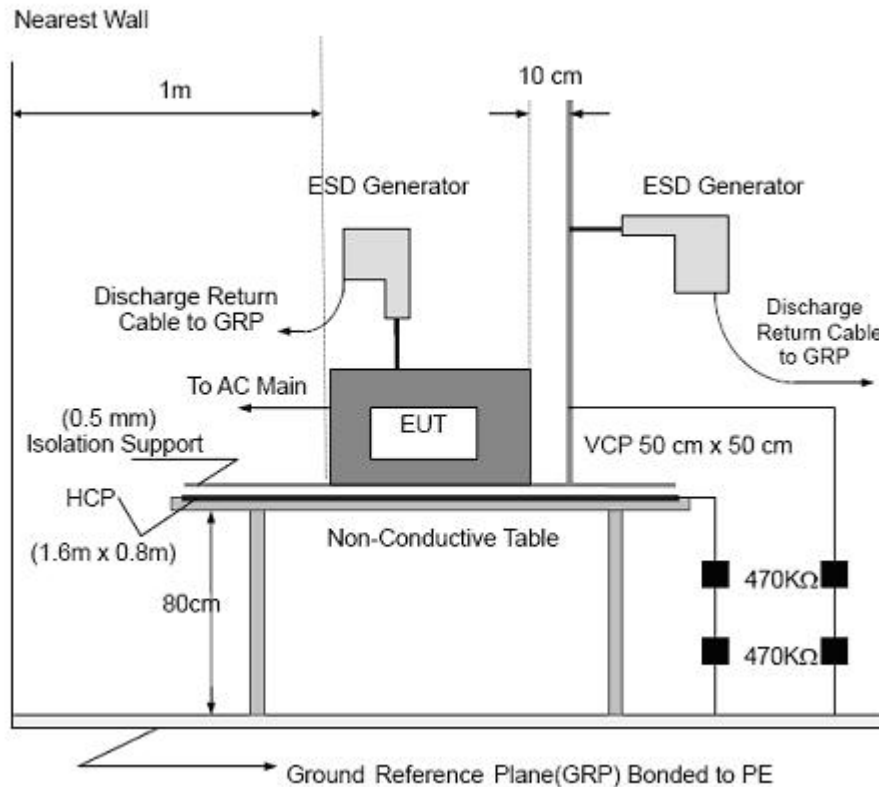

Note:

TABLE-TOP EQUIPMENT

The configuration consisted of a wooden table 0.8 meters high standing on the Ground Reference Plane. The GRP consisted of a sheet of aluminum at least 0.25mm thick, and 2.5 meters square connected to the protective grounding system. A Horizontal Coupling Plane (1.6m x 0.8m) was placed on the table and attached to the GRP by means of a cable with 940k total impedance. The equipment under test, was installed in a representative system as described in section 7 of IEC /EN 61000-4-2, and its cables were placed on the HCP and isolated by an insulating support of 0.5mm thickness. A distance of 1-meter minimum was provided between the EUT and the walls of the laboratory and any other metallic structure.

FLOOR-STANDING EQUIPMENT

The equipment under test was installed in a representative system as described in section 7 of IEC/EN 61000-4-2, and its cables were isolated from the Ground Reference Plane by an insulating support of 0.1-meter thickness. The GRP consisted of a sheet of aluminum that is at least 0.25mm thick, and 2.5meters square connected to the protective grounding system and extended at least 0.5 meters from the EUT on all sides.

4.3.4 TEST RESULTS

EUT :	Inverter/charger	Model Name. :	UP1000-M3212
Temperature :	25 °C	Relative Humidity :	45%
Pressure :	1010 hPa	Test Date :	2019-02-13
Test Mode :	Full Load		
Test Power :	DC48V		

Mode	Air Discharge								Contact Discharge								Criterion	Result
	4		8		10		15		2		4		6		8			
Test level (kV)																		
Test Location	+	-	+	-	+	-	+	-	+	-	+	-	+	-	+	-		
HCP									A	A	A	A					B	PASS
VCP									A	A	A	A						PASS
A1	A	A	A	A														PASS
A2	A	A	A	A														PASS

Note:

- 1) +/- denotes the Positive/Negative polarity of the output voltage.
- 2) Test condition:
 Direct / Indirect (HCP/VCP) discharges: Minimum 50 times (Positive/Negative) at each point. Air discharges: Minimum 10 times (Positive/Negative) at each point.
- 3) Test location(s) in which discharge (Air and contact discharge) to be applied illustrated by photos shown in next page(s)
- 4) The Indirect (HCP/VCP) discharges description of test point as following:
 1.left side 2.right side 3.front side 4.rear side
- 5) N/A - denotes test is not applicable in this test report

4.4 RS TESTING

4.4.1 TEST SPECIFICATION

Basic Standard:	IEC/EN 61000-4-3
Required Performance	A
Frequency Range:	80 MHz - 1000 MHz
Field Strength:	3 V/m
Modulation:	1kHz Sine Wave, 80%, AM Modulation
Frequency Step:	1 % of fundamental
Polarity of Antenna:	Horizontal and Vertical
Test Distance:	3 m
Antenna Height:	1.5 m
Dwell Time:	at least 3 seconds

4.4.2 TEST PROCEDURE

The EUT and support equipment, which are placed on a table that is 0.8 meter above ground and the testing was performed in a fully-anechoic chamber.

The testing distance from antenna to the EUT was 3 meters.

The other condition as following manner:

- a. The frequency range is swept from 80 MHz to 1000 MHz, & 1400MHz - 2700MHz with the signal 80%amplitude modulated with a 1kHz sine wave. The rate of sweep did not exceed 1.5x 10⁻³ decade/s. Where the frequency range is swept incrementally, the step size was 1% of fundamental.
- b. Sweep Frequency 900 MHz, with the Duty Cycle:1/8 and Modulation: Pulse 217 Hz(if applicable)
- c. The dwell time at each frequency shall be not less than the time necessary for the EUT to be able to respond.
- d. The test was performed with the EUT exposed to both vertically and horizontally polarized fields on each of the four sides.

4.4.3 TEST SETU

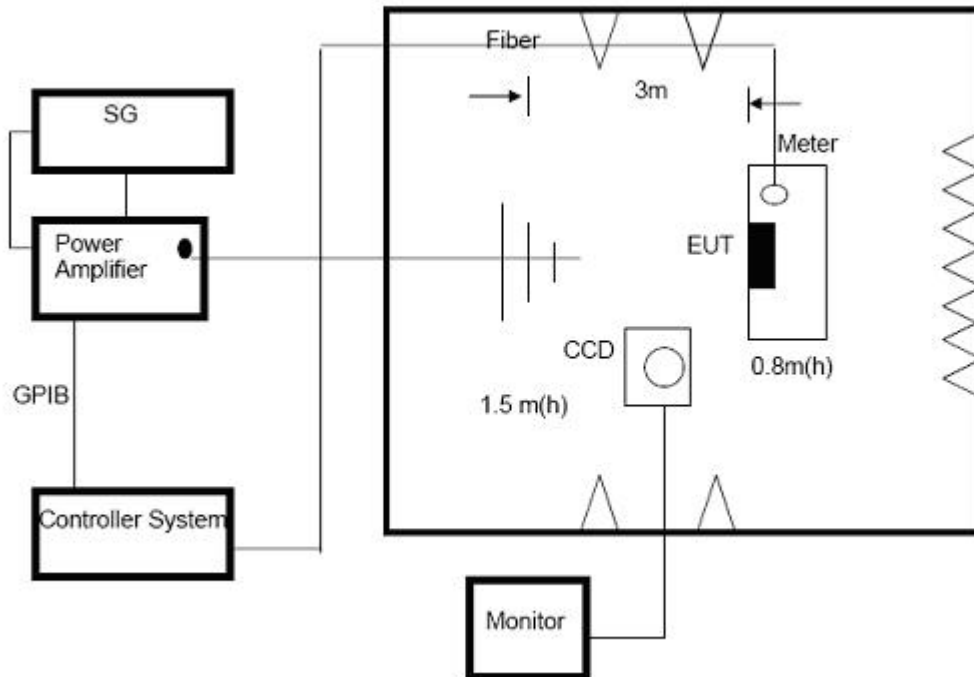

Note:

TABLE-TOP EQUIPMENT

The EUT installed in a representative system as described in section 7 of IEC/EN 61000-4-3 was placed on a non-conductive table 0.8 meters in height. The system under test was connected to the power and signal wire according to relevant installation instructions.

FLOOR-STANDING EQUIPMENT

The EUT installed in a representative system as described in section 7 of IEC/EN 61000-4-3 was placed on a non-conductive wood support 0.1 meters in height. The system under test was connected to the power and signal wire according to relevant installation instructions.

4.4.4 TEST RESULTS

EUT :	Inverter/charger	Model Name. :	UP1000-M3212
Temperature :	25 °C	Relative Humidity :	60%
Pressure :	1010 hPa	Test Date :	2019-02-13
Test Mode :	Full Load		
Test Power :	DC48V		

Frequency Range (MHz)	RF Field Position	R.F. Field Strength	Azimuth	Perform. Criteria	Results	Judgment
80MHz - 1000MHz	H / V	3 V/m (rms) AM Modulated 1000Hz, 80%	Front	A	A	PASS
			Rear			
			Left			
			Right			

Note:

- 1) N/A - denotes test is not applicable in this test report.
- 2) Criteria A: There was no change operated with initial operating during the test.
- 3) Criteria B: The EUT function loss during the test, but self-recoverable after the test.
- 4) Criteria C: The system shut down during the test.

ATTACHMENT PHOTOGRAPHS OF EUT
Photo 1



Photo 2

